

NEEP 427**PROPORTIONAL COUNTERS**

References: Knoll, Chapters 6 & 14 Sect. I & II

In a proportional counter the height of the output pulse is proportional to the number of ion pairs produced in the counter gas. Proportional counters are widely used as neutron detectors and, to a lesser extent, as β -ray detectors.

Equipment:

BF₃ neutron counter

Flow-type proportional counter (same as used for the Geiger Mueller experiment)

P-10 counting gas

High voltage supply

Preamplifier (Ensure the model you use allows you to apply the detector bias through the pre-amplifier. ORTEC Model 142 is an example. Remember to minimize the length of cabling between the preamp and the detector).

Amplifier

Single channel analyzer

Scaler

Multichannel analyzer

Oscilloscope

Neutron (PuBe) source, β -ray source (Au foils)

NOTE: There may not be enough equipment for every group to perform the two parts of the experiment in the same order.

Part A: Neutron Counters

1. Construct Neutron Moderating Cell

To obtain a thermal neutron flux, a neutron-moderating cell will need to be built. The general shape of this cell is shown in figure 2. A set of walls defining a rectangular floor is built out of lead bricks. A floor is built from interlocked lead bricks lined with paraffin. A Pu-Be source is placed on one end of the cell and the BF₃ detector on the other end. The cell is then filled with more paraffin and covered with lead bricks. The external radiation fields are limited to 6 mr/hr neutron and 0.4 mr/hr gamma. Be careful not to overbuild the moderating cell as you could shield out some of the neutrons you want to count.

The neutron source consists of metallic PuBe. (**PuBe sources may only be handled by instructor**). Alpha particles from Pu react with ⁹Be according to the following reaction: ${}^9\text{Be}(\alpha, n){}^{12}\text{C}$, producing neutrons of about 5.5 MeV which are moderated by paraffin or graphite surrounding the source. Thermal neutrons produce (n,α) reactions in ¹⁰B. (See Knoll, p. 519, for details). Most of the disintegrations leave ⁷Li in an excited state at 0.48 MeV.

- a. Draw a diagram of your cell and annotate your radiation survey around the cell exterior.

2. Connect Counting Electronics

The general electronics setup for this section is shown in figure 1. Connect a BF₃ counter to a preamplifier and amplifier and examine the amplifier output on an oscilloscope. Set the coarse gain on the amplifier to mid range (~“8” on the 485 or “100” on the 571). Connect the HV bias supply to counter through preamp. Gradually increase the HV until pulses from the amplifier reach about 2V (applied high voltages for this lab may run as high as 2000V). As the voltage is increased, the gas multiplication in the counter increases. Do

not raise the HV high enough to produce a discharge in counter. Most counters have marked on them normal operating voltage and maximum safe voltage.

- a. Draw the resulting pulse shapes as noted on the oscilloscope. **What is the sign of the pulse coming out of the preamplifier? How does this affect the settings on the counting electronics downstream of the preamplifier?**

3. Pulse Counting and Analysis

Connect the amplifier to the multichannel analyzer and record the pulse height distribution.

If the BF_3 counter is working properly, you should see a large peak corresponding to $^{10}\text{B}(n,\alpha)$ reactions leaving ^7Li in an excited state and a small peak at higher energy corresponding to disintegrations leaving ^7Li in the ground state.

- a. **Describe the pulse height distribution, including all peaks and plateaus.**
- b. Estimate the ratio of the pulse heights of the two peaks, and the ratio of the areas under the two peaks and **compare these ratios with expectations from the disintegration energies and from the cross sections.**

Connect output of the amplifier to an SCA and scaler. Set the amplifier gain in the middle of its range. Use the SCA as an integral discriminator. Measure the count rate as a function of the HV and raise the HV in 50V steps after some counts are observed. Be careful to not exceed the amplifier 10V limit as you increase the size of the pulse from the detector.

- a. Plot the count rate as a function of voltage. This is sometimes referred to as a “plateau curve”.
- b. Although a BF_3 counter usually gives a plateau, not all proportional counters

produce a plateau, in contrast to GM tubes. **Why? Explain in terms of the difference between pulse height distributions from the two types of counters.**

c. **In setting the discriminator level on the SCA, how did you handle the low-energy peak?**

4. Gas Gain

Measure the variation of gas gain with applied voltage. Set the HV near the beginning of the plateau and adjust the amplifier gain so that the peak in the pulse height distribution from the ${}^7\text{Li}^*$ ion occurs at $\sim 3\text{V}$ output. Use the MCA to locate the peak position. Change the HV applied to the detector to vary the pulse height over a range of approximately 0.5 to 8.0 volts. Plot pulse height (as determined with the MCA; i.e. 10 volts/1024 \times channel number) versus HV.

a. Obtain a relationship between gas gain and detector HV. Suggestion: Use either various types of graph paper (linear, semi-log, or log-log) or spreadsheet curve-fitting functions.

5. Moderation and Shielding

With the counter set at the plateau and a constant distance between source and detector, place varying amounts of paraffin between the source and detector (see figure 4).

a. Plot count rate as a function of paraffin thickness.
b. Study the effect of inserting sheets of Cd and paraffin in varying geometries between source and detector. **Explain observations qualitatively.**

Part B: Flow-type Proportional Counters

In this section, a flow-type proportional counter will be used to observe β rays from a ^{198}Au source. Connect the detector to the counting system following the schematic in figure 4.

1. Observing pulses from proportional counter.

Observe the amplifier output of the scope. Applied high voltage settings of roughly 1300-1900V may be required in this step. Raise the HV until the largest amplifier-output pulses reach about 10V, but be sure that pulses do not overload the amplifier. Use a triggered sweep. If the β -source is strong enough, more than one pulse will occur per sweep.

- a. **Observe the difference in the behavior of the proportional counter compared to the GM counter in response to high count rates.**

For the GM counter there is a dead-time, in a proportional counter a second pulse can occur very soon after the first, but the height of the second pulse may be different if it occurs before the first pulse has decayed.

- a. **Explain the difference between the proportional counter and Geiger-Mueller counter response to second pulses.**

Connect the amplifier output to the MCA and observe the pulse height distribution at several different high voltage settings. Remember the shape of a beta spectrum (Knoll p.4) when you analyze the spectrum.

- a. **On the basis of these observations, would you expect that the counter has a plateau?**

Check your prediction by connecting the amplifier output to an SCA and setting the integral discriminator at 0.1 volt and obtaining a "plateau curve" with the SCA.

- a. Plot the "plateau curve."

Was the 0.1V setting on the integral discriminator adequate to separate noise from signal?

Try adjusting the lower discriminator level.

- a. Compare the plateau curves obtained using different levels of discrimination.
- b. **How can you determine an optimum lower discriminator level?**

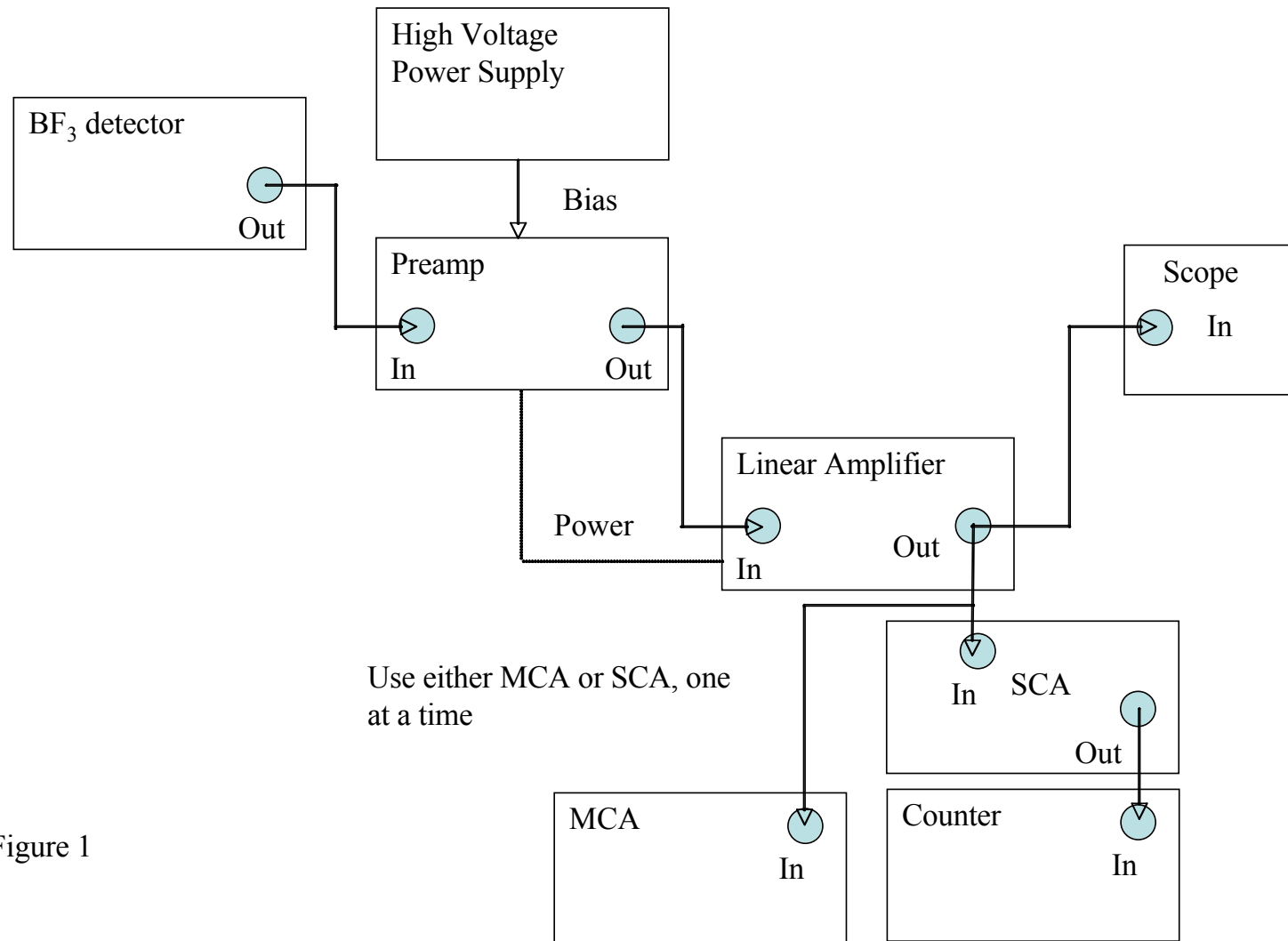

Figure 1

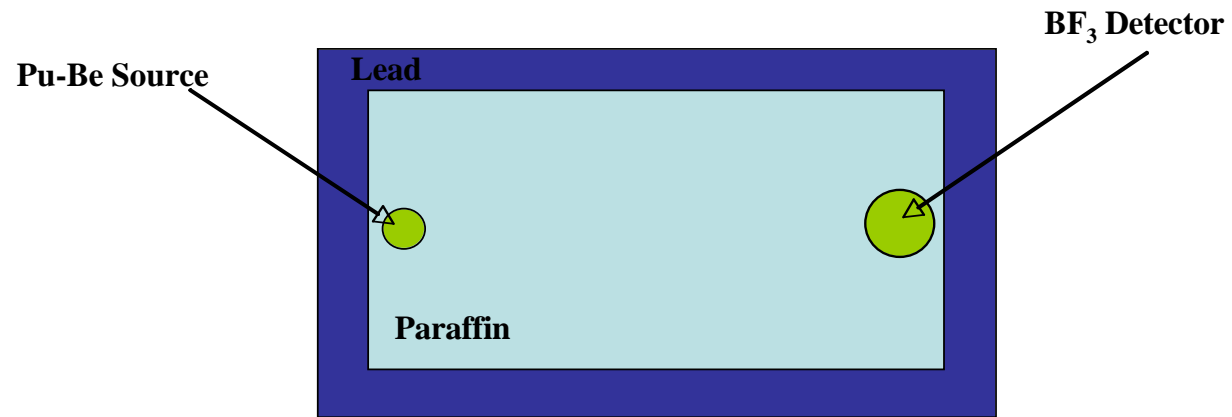

Figure 2

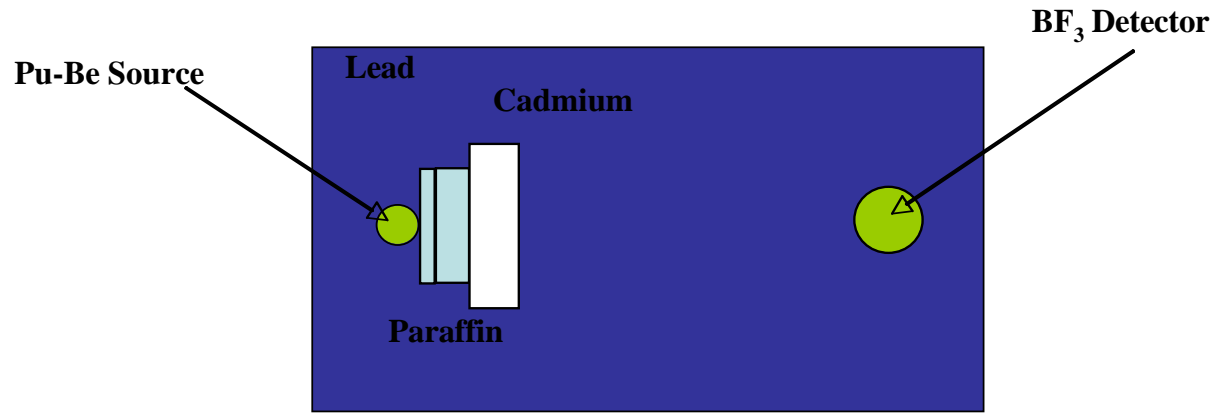

Figure 3

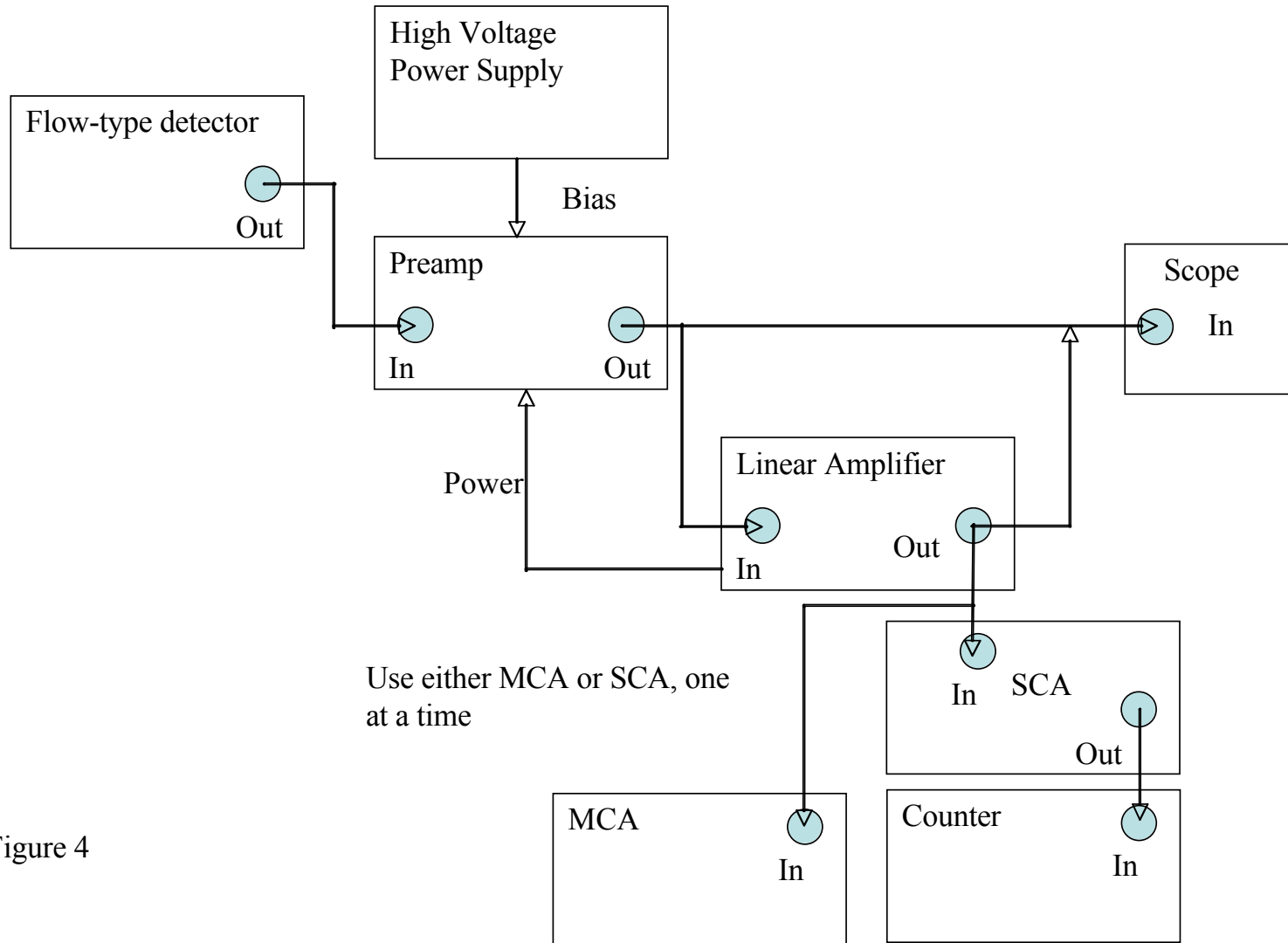

Figure 4