

ECE 376 Homework 4 – Solutions

Digital Homework Solutions

Prob 1) (a) Convert 101101.0101_2 to digital:

| | 2^5 | 2^4 | 2^3 | 2^2 | 2^1 | 2^0 | . | 2^{-1} | 2^{-2} | 2^{-3} | 2^{-4} |
|--------------|-------|-------|-------|-------|-------|-------|---|----------|----------|----------|----------|
| | 32 | 16 | 8 | 4 | 2 | 1 | . | 0.5 | 0.25 | 0.125 | 0.0625 |
| Enter Dig. # | 1 | 0 | 1 | 1 | 0 | 1 | . | 0 | 1 | 0 | 1 |
| Add this row | 32 | | 8 | 4 | | 1 | . | | 0.25 | | 0.0625 |

$$32 + 8 + 4 + 1 + 0.25 + 0.0625 = 45.3125$$

Answer: $101101.0101_2 = 45.3125_{10}$

(b) Convert 48.375_{10} to binary:

First convert the integer 48 to binary:

| | | | | | |
|-------------|---|-----------------------------|----|------------------|----------|
| $48 \div 2$ | = | | 24 | remainder | 0 |
| $24 \div 2$ | = | | 12 | remainder | 0 |
| $12 \div 2$ | = | | 6 | remainder | 0 |
| $6 \div 2$ | = | | 3 | remainder | 0 |
| $3 \div 2$ | = | | 1 | remainder | 1 |
| $1 \div 2$ | = | 0 (stop when this is zero!) | | remainder | 1 |

$$\text{So, } 48_{10} = 110000_2$$

Now convert the fraction 0.375 to binary:

| | | | | |
|------------------|---|----------|---|-----------------------------|
| 0.375×2 | = | 0 | . | 75 |
| 0.75×2 | = | 0 | . | 5 |
| 0.5×2 | = | 1 | . | 0 (stop when this is zero!) |

$$\text{So, } 0.375_{10} = 0.011_2$$

Answer: $48.375_{10} = 110000.011_2$

Prob 2) Convert 10011.011_2 to

(a) Decimal

| | 2^4 | 2^3 | 2^2 | 2^1 | 2^0 | . | 2^{-1} | 2^{-2} | 2^{-3} |
|--------------|-------|-------|-------|-------|-------|---|----------|----------|----------|
| | 16 | 8 | 4 | 2 | 1 | . | 0.5 | 0.25 | 0.125 |
| Enter Dig. # | 1 | 0 | 0 | 1 | 1 | . | 0 | 1 | 1 |
| Add this row | 16 | | | 2 | 1 | . | | 0.25 | 0.125 |

$$16 + 2 + 1 + 0.25 + 0.125 = 19.375$$

Answer: $10011.011_2 = 19.375_{10}$

(b) BCD

It's easier to convert decimal to BCD, so let's convert 19.375_{10} .

Note that in BCD:

- 0 = 0000
- 1 = 0001
- 2 = 0010
- 3 = 0011
- 4 = 0100
- 5 = 0101
- 6 = 0110
- 7 = 0111
- 8 = 1000
- 9 = 1001

| | | | | | |
|------|------|---|------|------|------|
| 1 | 9 | . | 3 | 7 | 5 |
| 0001 | 1001 | . | 0011 | 0111 | 0101 |

Answer: $19.375_{10} =$
 $0001\ 1001.0011\ 0111\ 0101$

Prob 3) Write an expression for Y and a truth table for the following circuit:

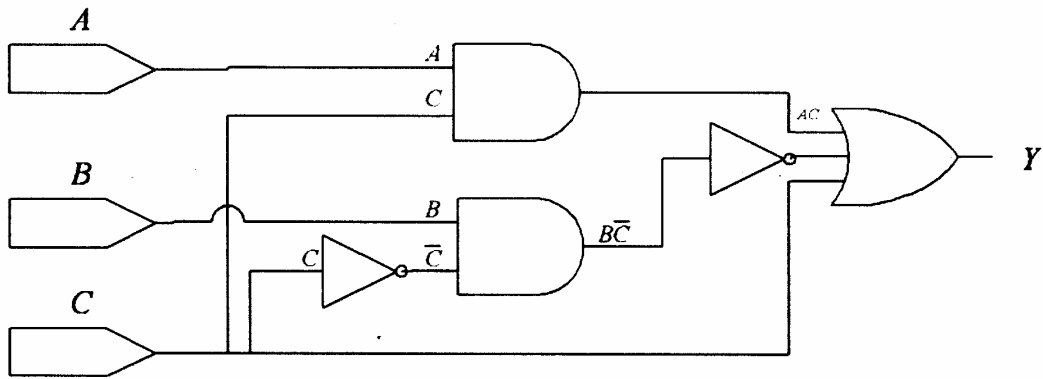

$$Y = AC + \overline{BC} + C$$

Work on table one column at a time.

| A | B | C | C' | AC | BC' | $(BC')'$ | Y |
|-----|-----|-----|------|------|-------|----------|-----|
| 0 | 0 | 0 | 1 | 0 | 0 | 1 | 1 |
| 0 | 0 | 1 | 0 | 0 | 0 | 1 | 1 |
| 0 | 1 | 0 | 1 | 0 | 1 | 0 | 0 |
| 0 | 1 | 1 | 0 | 0 | 0 | 1 | 1 |
| 1 | 0 | 0 | 1 | 0 | 0 | 1 | 1 |
| 1 | 0 | 1 | 0 | 1 | 0 | 1 | 1 |
| 1 | 1 | 0 | 1 | 0 | 1 | 0 | 0 |
| 1 | 1 | 1 | 0 | 1 | 0 | 1 | 1 |

Prob 4) The following are input waveforms to a D flip-flop. Draw the waveform for Q . The waveforms increase in time from left to right (first data in is at left). Keep in mind:

- (i) When $PR = CLR = 1$, Q follows D (the data input).
- (ii) When $PR = 0$ and $CLR = 1$, $Q = 1$.
- (iii) When $PR = 1$ and $CLR = 0$, $Q = 0$.
- (iv) When $PR = CLR = 0$, $Q = 1$ in a prohibited state.
- (v) Q responds to the changing inputs, only upon the clock's (CLK 's) next leading edge!!!

